

Solderless terminals

LIPPED BLADE *Non-insulated*

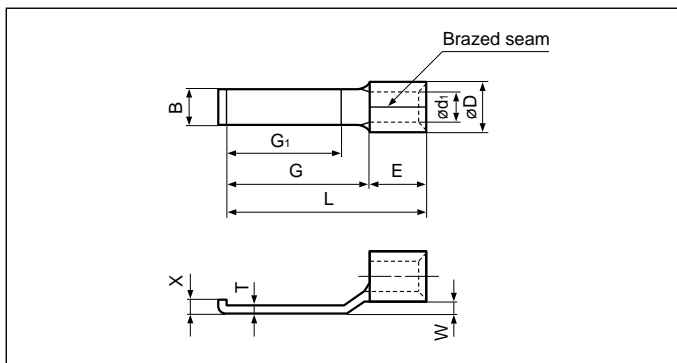

File No.: E42024

Applicable Wire AWG#(mm ²)	Part No.	Standard	Dimensions mm (in.)										Tool No.					Qty/box
			B	L	G	E	G ₁	ø D	ø d ₁	T	W	X	YHT-2210	YA-1	YA-2	YA-4	BCT-0514	
22 to 16 *(0.25 to 1.65)	AH-1.25		4.6 (.181)	21.6 (.850)	16.8 (.661)	4.8 (.189)	13.0 (.512)	3.4 (.134)	1.7 (.067)	0.8 (.031)	2.0 (.079)	1.7 (.067)	0	0	0	0	0	1,000
16 to 14 (1.04 to 2.63)	AH-2		4.6 (.181)	21.6 (.850)	16.8 (.661)	4.8 (.189)	13.0 (.512)	4.1 (.161)	2.3 (.091)	0.8 (.031)	2.0 (.079)	1.7 (.067)	0	0	0	0	0	1,000
12 to 10 (2.63 to 6.64)	AH-5.5		4.6 (.181)	23.6 (.929)	16.8 (.661)	6.8 (.268)	13.0 (.512)	5.6 (.220)	3.4 (.134)	0.8 (.031)	2.0 (.079)	1.9 (.075)	0	0	0	0	0	500

Note:1) The part numbers indicated in the above table are for products with a brazed seam.
 When ordering products with a butted seam, add the prefix "WS" to the part number (ex. AH-2 → **WSAH-2**).
 2) *The crimping will be more secure if the total cross-sectional area of the wire is at least 0.5 mm².
 Examples: If the cross-sectional area of the wire is 0.3mm², fold the wire in two when crimping the terminal.
 If the cross-sectional area of the wire is 0.5mm², crimp the terminal onto the wire as it is.
 3) Delivery lead times may vary depending on the product. Contact JST for details.

Solderless terminals

LIPPED BLADE *Vinyl-insulated*

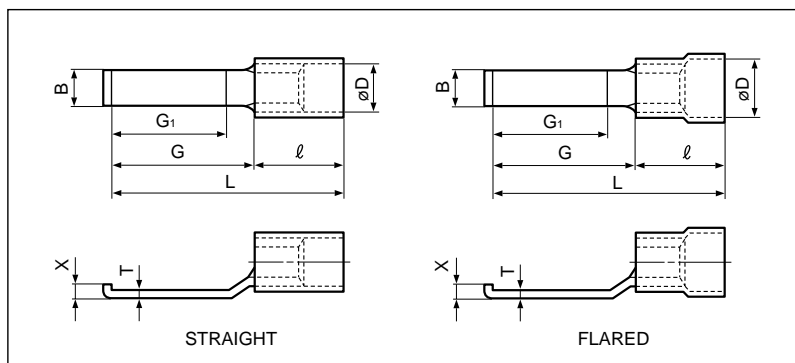
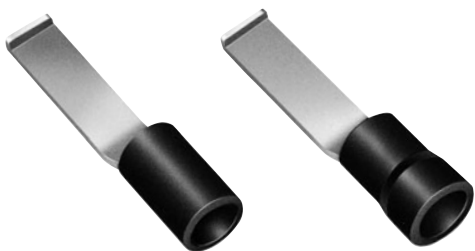

File No.: E42024

Applicable Wire AWG#(mm ²)	Part No.		Standard	Dimensions mm (in.)										Color	Tool No.					Qty/box	
	Straight	Flared		B	L	G	ℓ	G ₁	ø D		T	X	YHT-2216		YNT-1614	YNT-1210S	YA-1	YA-2	YA-4		BCT-0514
									Str.	Flid.											
22 to 16 *(0.25 to 1.65)	VAH-1.25	FVAH-1.25		4.6 (.181)	25.8 (1.016)	16.8 (.661)	9.0 (.354)	13.0 (.512)	3.2 (.126)	4.0 (.157)	0.8 (.031)	1.7 (.067)	Red	0		0	0	0	0	500	
16 to 14 (1.04 to 2.63)	VAH-2	FVAH-2		4.6 (.181)	25.8 (1.016)	16.8 (.661)	9.0 (.354)	13.0 (.512)	3.9 (.154)	4.5 (.177)	0.8 (.031)	1.7 (.067)	Blue	0		0	0	0	0	500	
12 to 10 (2.63 to 6.64)	VAH-5.5	FVAH-5.5		4.6 (.181)	30.3 (1.193)	16.8 (.661)	13.5 (.531)	13.0 (.512)	5.4 (.213)	6.8 (.268)	0.8 (.031)	1.9 (.075)	Yellow		0			0	0	250	

Note:1) The part numbers indicated in the above table are for products with a brazed seam.
 When ordering products with a butted seam, add the prefix "WS" to the part number (ex. VAH-2 → **VWSAH-2**).
 2) *The crimping will be more secure if the total cross-sectional area of the wire is at least 0.5 mm².
 Examples: If the cross-sectional area of the wire is 0.3mm², fold the wire in two when crimping the terminal.
 If the cross-sectional area of the wire is 0.5mm², crimp the terminal onto the wire as it is.
 3) Delivery lead times may vary depending on the product. Contact JST for details.

Solderless terminals

LIPPED BLADE Vinyl-insulated (funnel-entry)

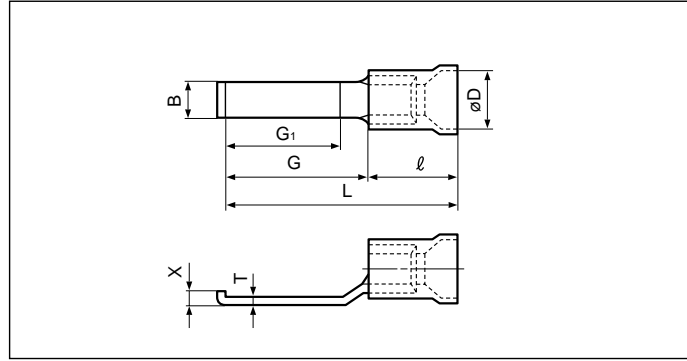

File No.: E42024

Applicable Wire AWG#(mm ²)	Part No.	Standard	Dimensions mm (in.)								Color	Tool No.						Qty/box	
			B	L	G	l	G ₁	ø D	T	X		YNT-2216	YNT-1614	YNT-1210S	YA-1	YA-2	YA-4		BCT-0514
22 to 16 *(0.25 to 1.65)	FVLAH-1.25	UL	4.6 (.181)	26.2(1.031)	16.8 (.661)	9.4 (.370)	13.0 (.512)	4.2 (.165)	0.8 (.031)	1.7 (.067)	Red	o			o	o	o	o	1,000
16 to 14 (1.04 to 2.63)	FVLAH-2	UL	4.6 (.181)	26.2(1.031)	16.8 (.661)	9.4 (.370)	13.0 (.512)	4.7 (.185)	0.8 (.031)	1.7 (.067)	Blue		o		o	o	o	o	1,000
12 to 10 (2.63 to 6.64)	FVLAH-5.5	UL	4.6 (.181)	30.6(1.205)	16.8 (.661)	13.8 (.543)	13.0 (.512)	6.8 (.268)	1.0 (.039)	1.9 (.075)	Yellow			o			o	o	500

- Note:1) The part numbers indicated in the above table are for products with a brazed seam.
 When ordering products with a butted seam, add the prefix "WS" to the part number (ex. FVLAH-2 ->FVLWSAH-2).
 2) *The crimping will be more secure if the total cross-sectional area of the wire is at least 0.5 mm².
 Examples: If the cross-sectional area of the wire is 0.3mm², fold the wire in two when crimping the terminal.
 If the cross-sectional area of the wire is 0.5mm², crimp the terminal onto the wire as it is.
 3) Delivery lead times may vary depending on the product. Contact JST for details.

Solderless terminals

LIPPED BLADE Vinyl-insulated with copper sleeve

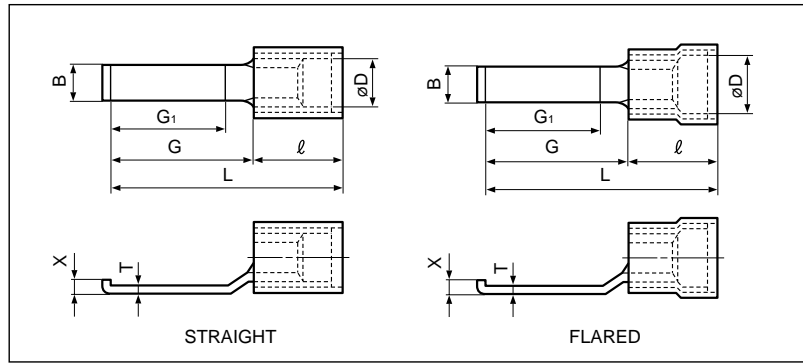
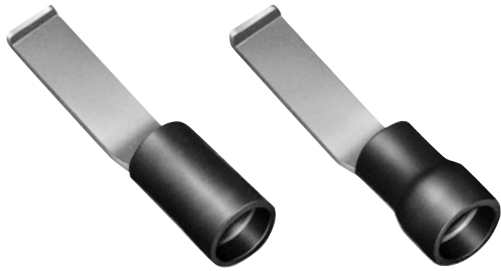

File No.: E42024

Applicable Wire AWG#(mm ²)	Part No.		Standard	Dimensions mm (in.)								Color	Tool No.						Qty/box			
	Straight	Flared		B	L	G	l	G ₁	ø D		T		X	YNT-2216	YNT-1614	YNT-1210S	YA-1	YA-2		YA-4	BCT-0514	
									Str.	Fld.												
22 to 16 (0.25 to 1.65)	VDAH-1.25	FVDAH-1.25	UL	4.6 (.181)	26.4 (1.039)	16.8 (.661)	9.6 (.378)	13.0 (.512)	3.5 (.138)	4.0 (.157)	0.8 (.031)	1.7 (.067)	Red	o			o	o	o	o	o	500
16 to 14 (1.04 to 2.63)	VDAH-2	FVDAH-2	UL	4.6 (.181)	26.4 (1.039)	16.8 (.661)	9.6 (.378)	13.0 (.512)	4.1 (.161)	4.7 (.185)	0.8 (.031)	1.7 (.067)	Blue		o		o	o	o	o	o	500
12 to 10 (2.63 to 6.64)	VDAH-5.5	FVDAH-5.5	UL	4.6 (.181)	30.8 (1.213)	16.8 (.661)	14.0 (.551)	13.0 (.512)	5.7 (.224)	6.5 (.256)	1.0 (.039)	1.9 (.075)	Yellow			o			o	o	o	250

- Note:1) The part numbers indicated in the above table are for products with a brazed seam.
 When ordering products with a butted seam, add the prefix "WS" to the part number (ex. FVDAH-2 ->FVDWSAH-2).
 2) Delivery lead times may vary depending on the product. Contact JST for details.