

# HM CONNECTOR

2.5mm pitch/Wire-to-wire connectors - Matable with HR receptacles

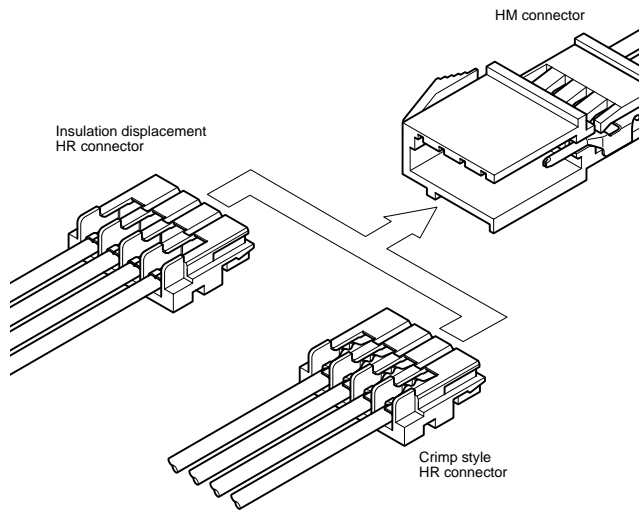

- Both crimp style and insulation displacement receptacles can be used
- Housing-to-terminal locks
- Mountable on a variety of panels
- Highly reliable housing construction

## Specifications

- Current rating: Crimp style HR connectors type  
3A AC, DC max.  
Insulation displacement HR connectors type  
2A AC, DC max.
- Voltage rating: 250V AC, DC max. (See Note below.)
- Temperature range: -25°C to +85°C  
(including temperature rise in applying electrical current)
- Contact resistance: Initial value/10m Ω max.  
After environmental testing/20m Ω max.
- Insulation resistance: 500M Ω min.
- Withstanding voltage: 1,000V AC/minute
- Applicable wire: AWG #26 to #22  
0.13 to 0.33mm<sup>2</sup>
- Applicable panel thickness: 0.8 to 1.6mm

Note: Contacts are exposed at the housing lances.

Care should be taken so that these parts do not touch the metal section of the chassis.

- \* RoHS compliant products are published.
- \* Refer to "General Instruction and Notice when using Terminals and Connectors" at the end of this catalog.
- \* Contact JST for details.

## Standards

Recognized E60389

Certified LR20812

## Panel layout and Assembly layout

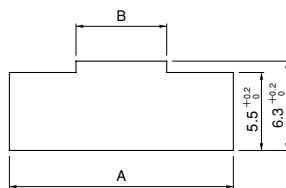
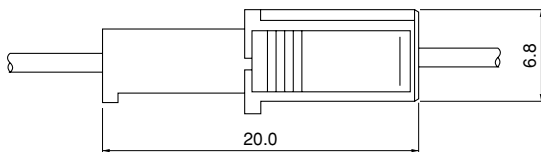

Circuits	Housing	Panel hole dimensions (mm) General tolerance		Applicable panel thickness (mm)
		A $^{+0.2}_0$	B $^{+0.2}_0$	
2	HMR-02V	13.3	3.9	0.8 ~ 1.6
3	HMR-03V	15.8	6.4	
4	HMR-04V	18.3	8.9	
8	HMR-08V	28.3	18.9	
12	HMR-12V	38.3	28.9	

- Note: 1. Punch holes in the panel according to the sketch and table shown above. Burrs must be removed.  
2. The strength of the panel must be considered when punching two or more holes.  
3. The connector must be inserted from the same side as the hole is punched.

## Plug / HM connector

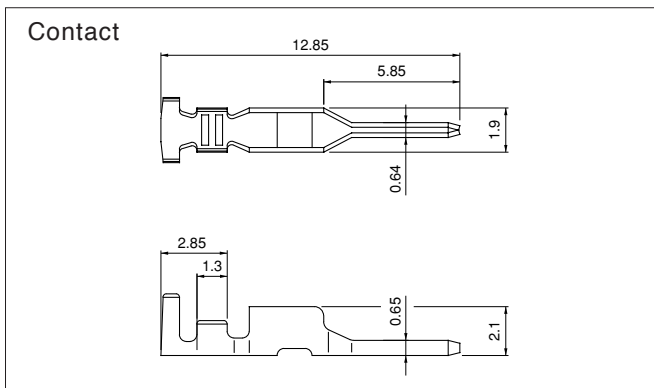

Model No.	Applicable wire		Insulation O.D. (mm)	Q'ty / reel
	mm <sup>2</sup>	AWG #		
<b>SMR-001T-0.6</b>	0.13~0.33	26~22	1.3~1.7	9,000

### Material and Finish

Brass, tin-plated (reflow treatment)

### RoHS compliance

Contact	Crimping machine	Applicator		
		Crimp applicator	Dies	Crimp applicator with dies
<b>SMR-001T-0.6</b>	AP-K2N	MKS-L	MK/SHR/MR-001-06	APLMK SHR/MR001-06
		*MKS-SC	SC/SHR/MR-001-06	APLSC SHR/MR001-06

Note: \*Strip-crimp applicator

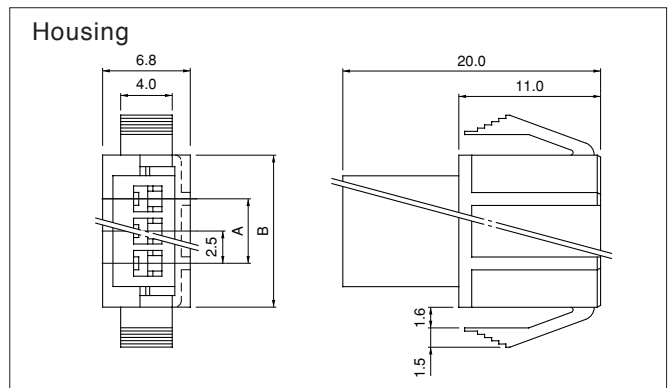

Circuits	Model No.	Dimensions (mm)		Q'ty / bag
		A	B	
2	<b>HMR-02V</b>	2.5	9.3	1,000
3	<b>HMR-03V</b>	5.0	11.8	500
4	<b>HMR-04V</b>	7.5	14.3	500
8	<b>HMR-08V</b>	17.5	24.3	500
12	<b>HMR-12V</b>	27.5	34.3	500

### Material

PA 66, UL94V-0

### RoHS compliance

## Receptacle / Crimp style HR connector

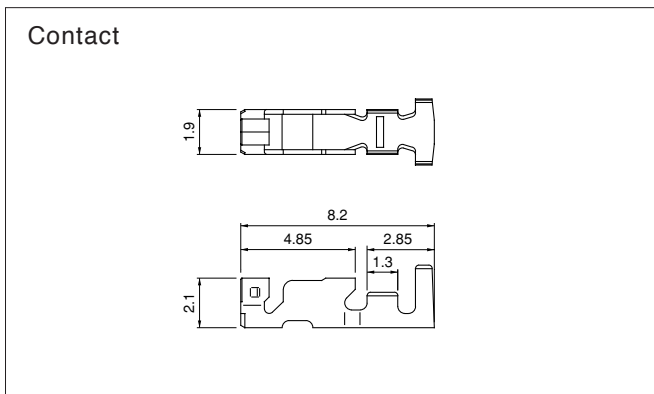

Model No.	Applicable wire		Insulation O.D. (mm)	Q'ty / reel
	mm <sup>2</sup>	AWG #		
<b>SHR-001T-P0.6</b>	0.13~0.33	26~22	1.3~1.7	9,000

### Material and Finish

Phosphor bronze, tin-plated (reflow treatment)

### RoHS compliance

Contact	Crimping machine	Applicator		
		Crimp applicator	Dies	Crimp applicator with dies
<b>SHR-001T-P0.6</b>	AP-K2N	MKS-L	MK/SHR/MR-001-06	APLMK SHR/MR001-06
		*MKS-SC	SC/SHR/MR-001-06	APLSC SHR/MR001-06

Note: \*Strip-crimp applicator

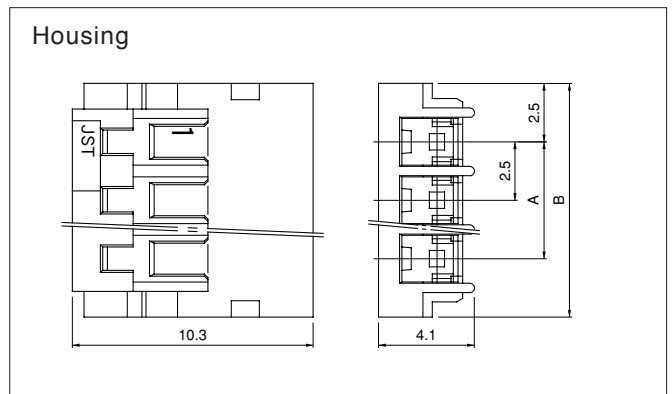

Circuits	Model No.	Dimensions (mm)		Q'ty / bag
		A	B	
2	<b>HRP-02-S</b>	2.5	7.5	2,000
3	<b>HRP-03-S</b>	5.0	10.0	2,000
4	<b>HRP-04-S</b>	7.5	12.5	1,000
8	<b>HRP-08-S</b>	17.5	22.5	500
12	<b>HRP-12-S</b>	27.5	32.5	500

### Material

PA 66, UL94V-0

### RoHS compliance

# HM CONNECTOR

## Receptacle/Insulation displacement HR connector

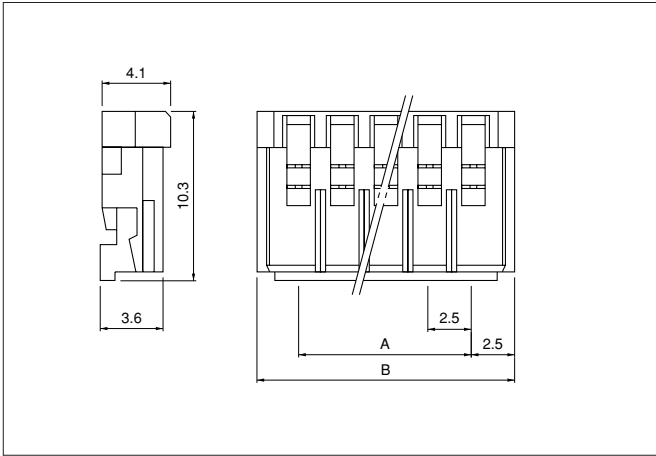

Circuits	Model No.			Dimensions (mm)		Qty / bag
	# 28	# 26	# 24	A	B	
2	02HR-8M-P-N	02HR-6S-P-N	02HR-4K-P-N	2.5	7.5	1,000
3	03HR-8M-P-N	03HR-6S-P-N	03HR-4K-P-N	5.0	10.0	1,000
4	04HR-8M-P-N	04HR-6S-P-N	04HR-4K-P-N	7.5	12.5	1,000
8	08HR-8M-P-N	08HR-6S-P-N	08HR-4K-P-N	17.5	22.5	500
12	12HR-8M-P-N	12HR-6S-P-N	12HR-4K-P-N	27.5	32.5	500

### Material and Finish

Contact: Phosphor bronze, tin-plated (reflow treatment)  
Housing: PA 66, UL94V-0

### RoHS compliance